

## Stainless Steel Washdown Bench & Platform Scale

- Large Display



Model	FS-60	FS-150	FS-300
Capacity	60 kg / 132 lb	150 kg / 330 lb	300 kg / 660 lb
Readability	0.01 kg / 0.02 lb	0.02 kg / 0.05 lb	0.05 kg / 0.1 lb
Divisions	6,000	7,500	6,000
Weighing Units / Functions	kg / lb / lb : oz		
Stabilization Time (seconds)	< 1.5		
Tare Range	To capacity by subtraction		
Power Source	Built-in rechargeable battery or external power adaptor (included)		
Construction	Stainless steel platform, pillar, indicator and housing (Aluminum load receiving structure)		
Display	2 inch / 51 mm wide viewing angle LCD		
Platform Size (w x h x d)	16.7 x 4.7 x 20.7 inches / 425 x 120 x 525 mm		
Dimensions (w x h x d)	16.7 x 36.8 x 20.7 inches / 425 x 935 x 525 mm		
Operating Environment	32° ~ 104° F non condensing R.H. ≤ 85%		
Net Weight	48.4 lb / 22 kg		
Shipping Weight	50.6 lb / 23 kg		
Nema / IP Rating	IP 65		
Options	LED backlight		

### Features

- All stainless steel housing and pan
- Heavy duty construction
- Sealed electronics. Waterproof tactile keypad
- Low profile
- Large LCD display with wide angle viewing
- Extendable pillar (another 5.5 inches / 140 mm)
- Reads in kilograms, pounds and pounds : ounces
- Built-in rechargeable battery or external power adaptor
- Accumulation function
- Zero tracking
- Automatic power save
- Low battery indicator
- Auto-calibration function
- Adjustable stainless steel feet with rubber inserts
- Indicator rotates through 135 degrees

### Benefits

- Easy to clean for food processing or harsh environments
- Will withstand harsh industrial operation
- Improved water and dust resistance, spraydown capable
- Easy to load and unload platform only 4.7 inches / 120 mm high
- Easy to see weight values from a distance, reduces mistakes
- Enables bulky objects to be weighed
- Flexibility of operation
- Portability - battery lasts a minimum of 120 hours (without back light)
- Allows you to add together consecutive weights to arrive at a total
- Assures that you always start weighing at zero
- Conserves battery power
- Alerts you to charge the battery, saving downtime
- Ensures accuracy
- Balance remains level for accurate results on uneven working surfaces - anti-slip
- Enables viewing from all angles

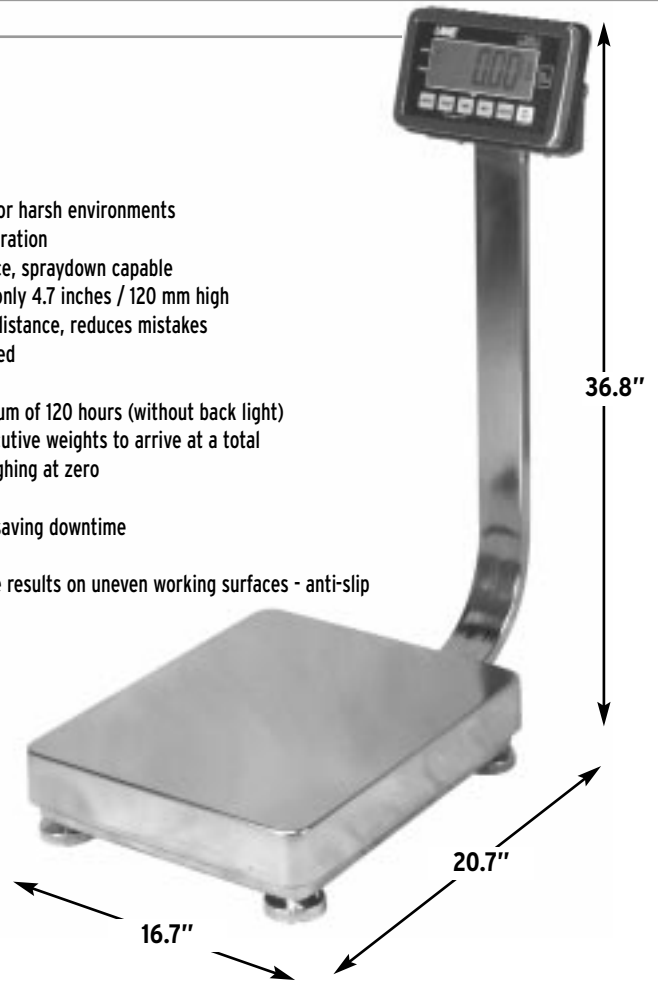

Call Us Today!  
800-836-8445